

Standard Pump
Product Catalog



Delivering the heaviest duty slurry pumps for all solids handling applications.

Schurco Slurry® has engineered products and services to deliver the highest performance at the best value for our customers in mining, dredging, quarrying, and industrial processing around the world. With pumps and support centers on six continents, reliable service is just a phone call away.



Hard-Rock Mining

Gold, copper, iron, silver, polymetallic, and other hard-rock ores requiring extraction and wet-processing

Mineral Processing

Coal preparation, frac sand processing, phosphate, alumina, kaolin clay, soda ash, diatomaceous earth, and others



Aggregates

Construction minerals of all types, sand, gravel, concrete, dredging, and more

Power

Flue-gas desulfurization, lime slurry circuits, bottom and top ash



Industrial

Pulp & paper, steel mills, slag processing, metal recycling, metal refineries, food processing, and sugar

Solids Handling

Wherever solids are pumped, Schurco Slurry® pumps can move the mixture

Schurco Slurry® pump designs cover a wide range of applications with diverse materials, seals, and hydraulic performance for the most rigorous duties. Each pump series has distinct design features to deliver maximum performance for your particular application.

HORIZONTAL PUMPS

Exploded Views	2
Horizontal Pump Seal Options	3
S-Series	4
<i>severe duty, lined pump, designed for the entire mill or plant; an all-around workhorse pump suitable for all Slurry Classes (I, II, III, and IV)</i>	
L-Series	5
<i>heavy-duty lined pump, with higher efficiencies than the S Series, suitable for Slurry Classes I, II, and III</i>	
H-Series	6
<i>extremely robust metal-lined pump for high-head and series applications including long distance hydrotransport and filter press applications</i>	
U-Series	7
<i>unlined and cost-effective pump with a solid bowl metal wet-end; simple design makes for easy maintenance</i>	
P-Series	8
<i>ideal for use in "dirty water" and light slurry applications, this pump series provides the end user with the ultimate in reliability</i>	
Z-Series	9
<i>rough and ready, this large solids capacity design is perfect for dredging or large particle pumping</i>	

VERTICAL PUMPS

Sectional View, Metal Pump	10
Sectional View, Elastomer Pump	11
V-Series	12
<i>fully-cantilevered pump design, with no submerged bearings; can operate completely dry with no ill effect</i>	



Horizontal Pump Components

SERIES S, H, AND L

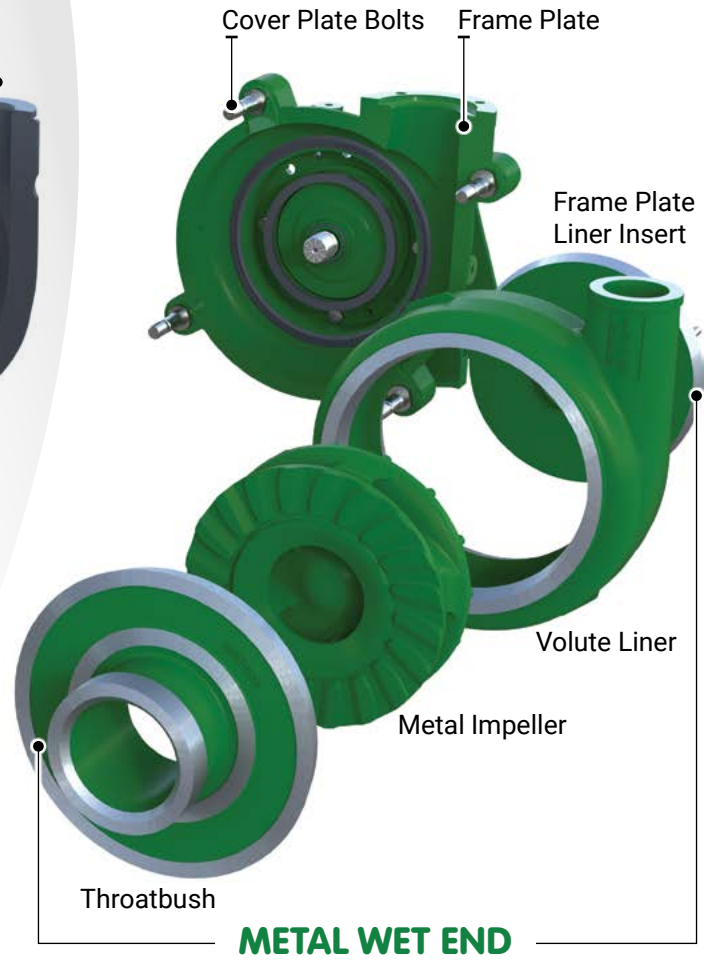

UNLINED PUMP COMPONENTS

SERIES U, P, AND Z

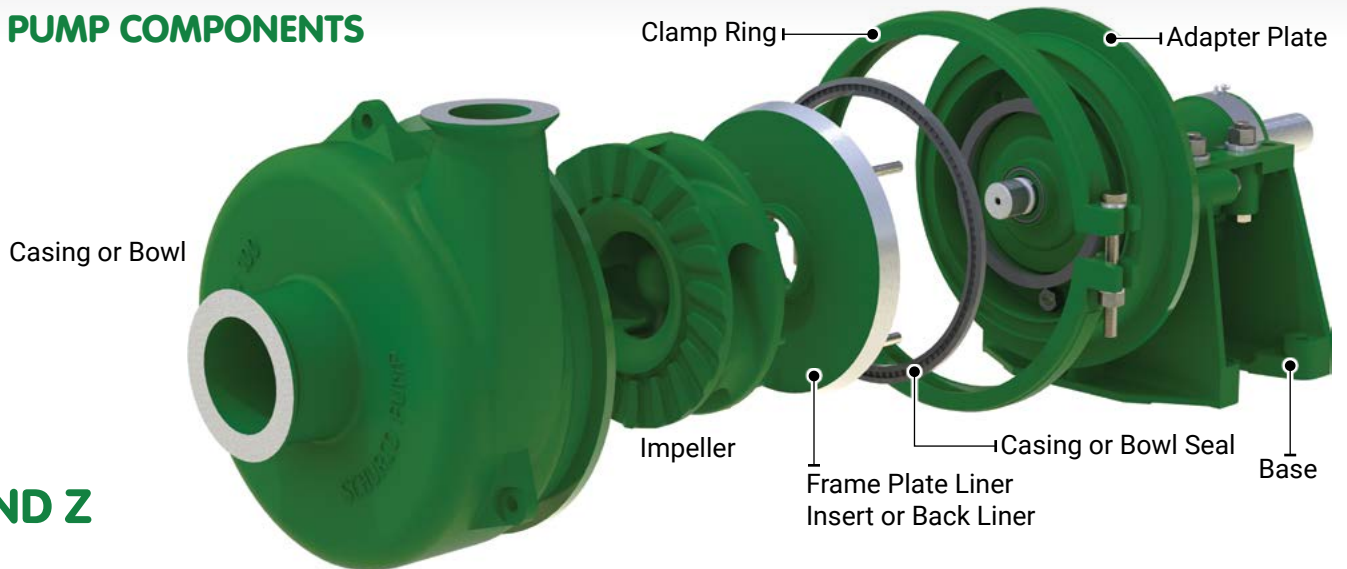

Seal Options

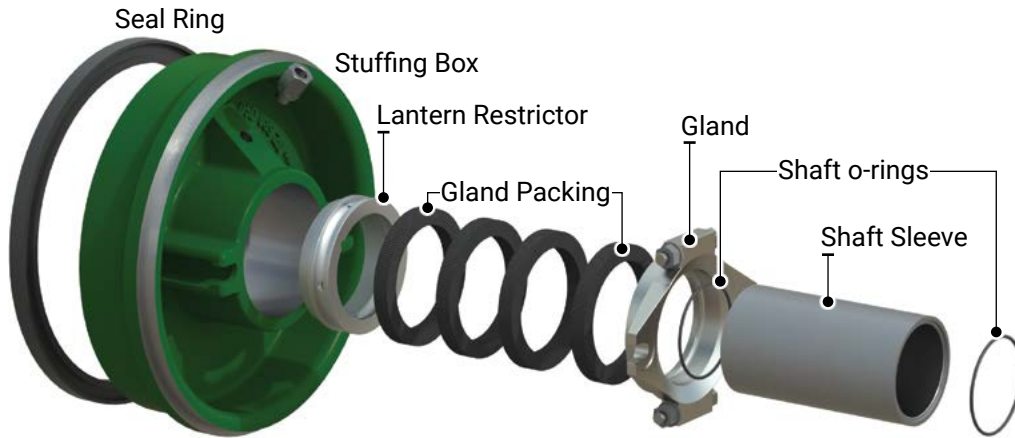

STUFFING BOX SEALS

The stuffing box is the original shaft seal for any rotating element through a fixed device. This seal has stood the test of time, and is still one of the most common sealing arrangements in slurry pumps.

Seal water must be supplied at a pressure in excess of pump discharge pressure.

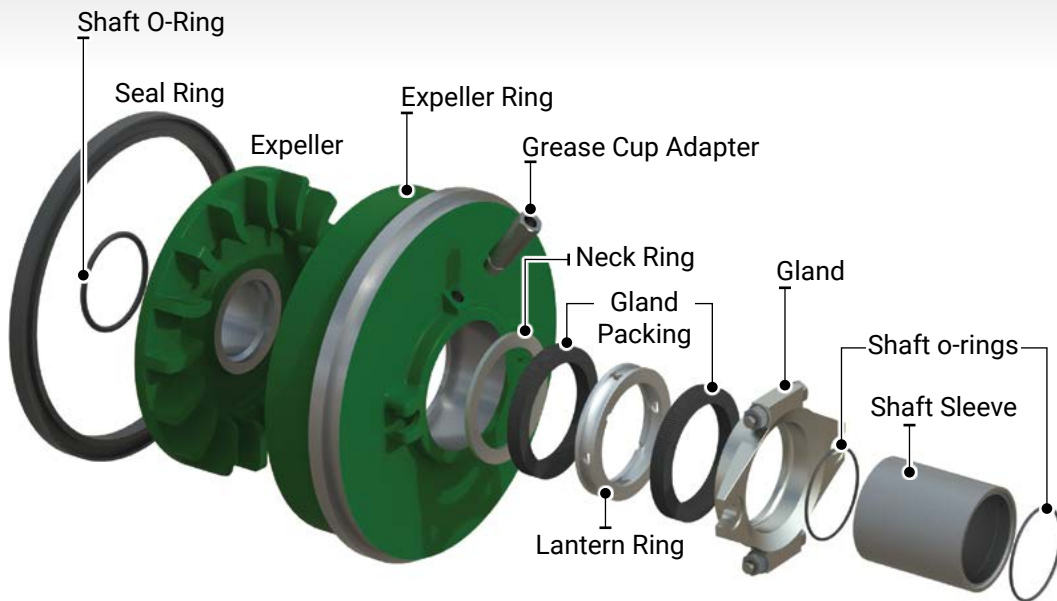

EXPELLER OR CENTRIFUGAL SEALS

The Schurco expeller seal can operate completely leak free during pump operation. The expeller rides along the shaft and *expels* material from the expeller ring cavity. Consideration must be given to inlet pressure and pump speed to ensure proper sealing with this type of seal arrangement.

The typical installation introduces grease in lieu of seal water to provide a static seal against the inlet pressure when the pump is not operating.

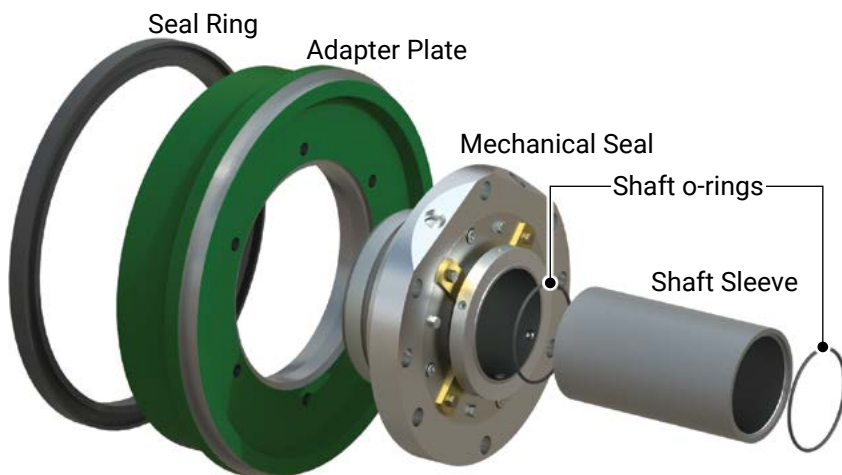

MECHANICAL SEALS

A mechanical seal consists of two principle components. One component is stationary and the other rotates against it to achieve a seal. There are many types of mechanical seals, ranging from simple single spring designs to considerably more complex cartridge seal types, which are the type most commonly applied on slurry pumps. The design, arrangement and materials of construction are essentially determined by the pressure, temperature, speed of rotation and product being sealed (the slurry).

S Series

Severe duty, lined pump, designed for the entire mill or plant; an all-around workhorse pump suitable for all Slurry Classes (I, II, III, and IV).

With a wide variety of impeller designs, material selections, and shaft sealing options, the Schurco S Series pump can pump high solids at high heads in corrosive duties. Its simple and easy to maintain construction offers the best life-cycle cost on the market today.



HYDRAULIC COVERAGE

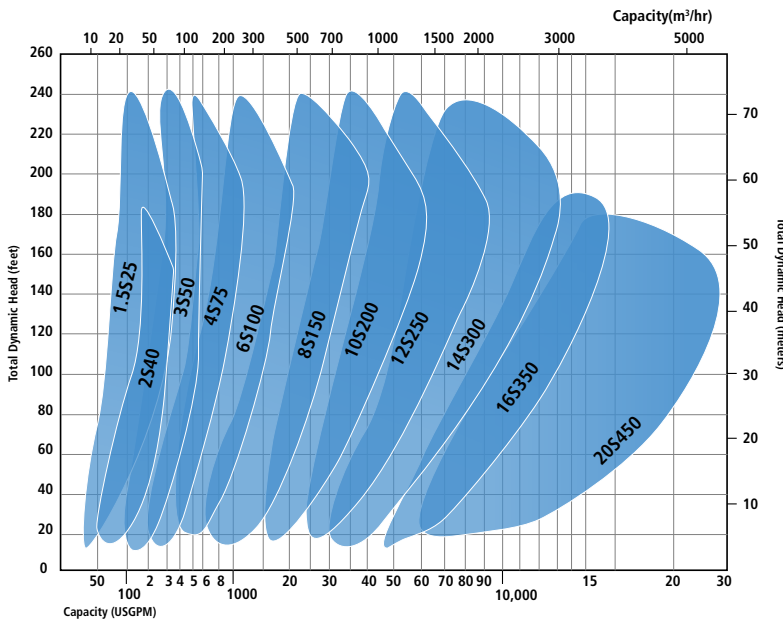

PROFILE

Discharge range: 1" to 18" [25mm to 450mm]

Heads to: 240 ft [73 m]

Flows to: 22,000 gpm [5,000 m³/hr]

Working pressures to: 300 psig [2070 kPa]

Typical Applications

- Ore Transport
- Mill Discharge
- Cyclone Feed
- Tailings
- Plant Process
- Heavy Media
- Coal Preparation
- Coarse and fine aggregate

FEATURES

- Variety of high efficiency and non-clog impeller designs with pump-out vanes on shrouds to improve seal performance
- Zero leakage pumping available with Schurco Expeller Seals that do not require seal water
- Diverse range of materials for all wear components to maximize operational life in abrasive or corrosive slurries
- Oversized shaft diameters and reduced overhang in the wet-end contribute to long life and reliability from drive-end in the field

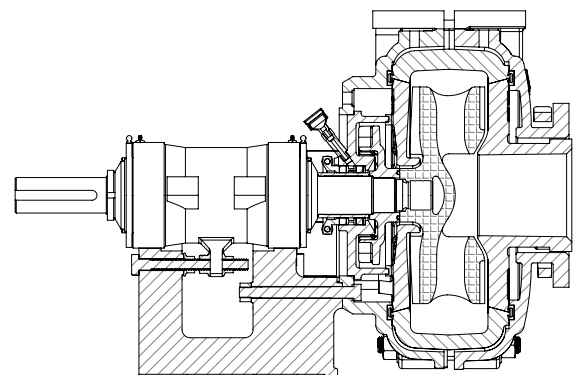

L Series

Heavy-duty lined pump, with higher efficiencies than the S Series, suitable for Slurry Classes I, II, and III.

Higher efficiency, volume focused impellers deliver world class performance for Slurry Classes III and below. Reaching heads of nearly 200 ft, this pump delivers solid pumping performance for a wide variety of applications.



HYDRAULIC COVERAGE

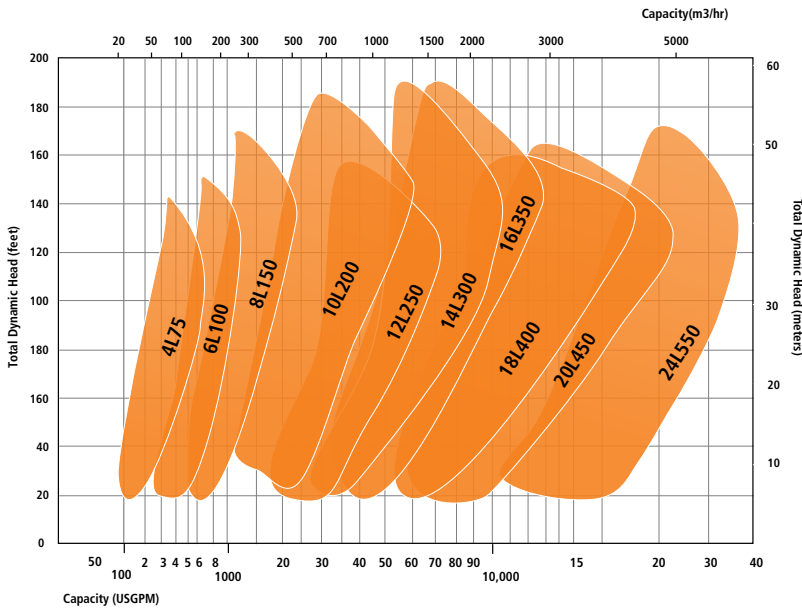

PROFILE

Discharge range: 4" to 22" [100 mm to 550 mm]

Heads to: 180 ft [55 m]

Flows to: 30,000 gpm [6,800 m³/hr]

Working pressures to: 250 psig [1,725 kPa]

Typical Applications

- Aggregates
- FGD applications
- Mineral Processing
- Mine Dewatering
- Cyclone Feed
- Coal preparation
- Process
- Ash handling

FEATURES

- High efficiency impellers deliver greater flowrates at lower operating costs
- Expansive internal clearances to reduce internal velocities increase wear life and reduce wear part consumption
- Zero leakage pumping available with Schurco Expeller Seals that do not require seal water
- Diverse range of materials for all wear components to maximize operational life in abrasive or corrosive slurries
- Oversized shaft diameters and reduced overhang in the wet-end contribute to long life and reliability from drive-end in the field

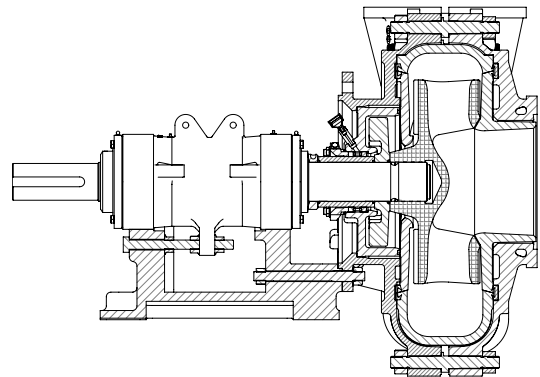

H Series

Extremely robust metal-lined pump for high-head and series applications including long distance hydrotransport and filter press applications.

Extensive exterior ribbing allows for higher heads to be reached with a single pump, and bulked up wet end parts handle the toughest applications in the field today. High impeller aspect ratios allow the pumps to deliver higher pressures at lower pump RPM's to increase wear and service life in the toughest applications.



HYDRAULIC COVERAGE

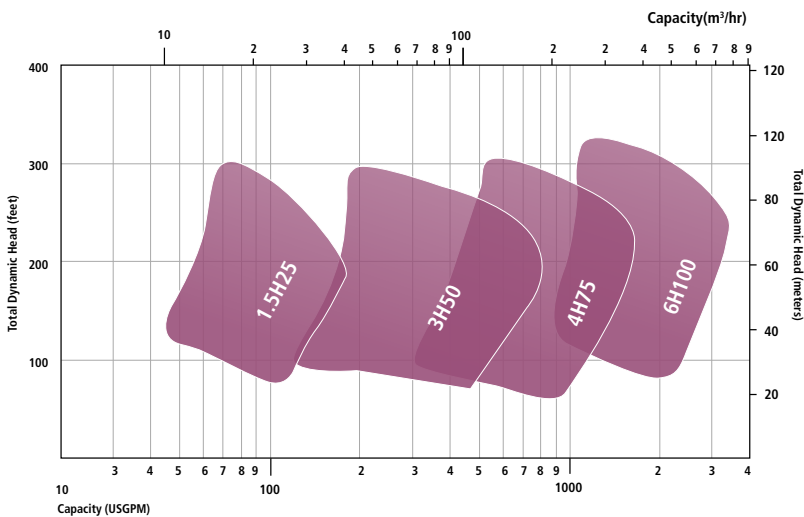

PROFILE

Discharge range: 1" to 6" [25 mm to 150 mm]

Heads to: 325 ft [100 m]

Flows to: 3,000 gpm [700 m³/hr]

Working pressures to: 750 psig [5170kPa]

Typical Applications

- Filter press feed
- Tailings disposal
- Series Pumping
- Pipeline Transport

FEATURES

- Extra-thick liners and impeller shrouds for maximum wear life
- Balanced efficiency and wear life for applications with highly abrasive material
- Zero leakage pumping available with Schurco Expeller Seals that do not require seal water
- Diverse range of metallurgical materials for all wear components to maximize operational life in abrasive or corrosive slurries
- Oversized shaft diameters and reduced overhang in the wet-end contribute to long life and reliability from drive-end in the field
- High pressure stuffing boxes available for series pumping

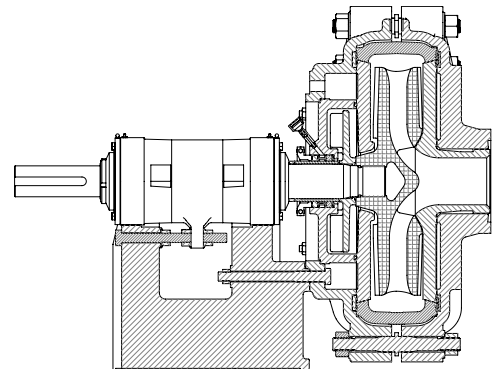

U Series

Unlined and cost-effective pump with a solid bowl metal wet-end; simple design makes for easy maintenance.

Solid bowl pumps with many metallurgical options and large impeller diameters provide durability, strength, and long service life. The U series is built around a proven bearing frame and base, which is used throughout the range of Schurco Slurry® pumps.



HYDRAULIC COVERAGE

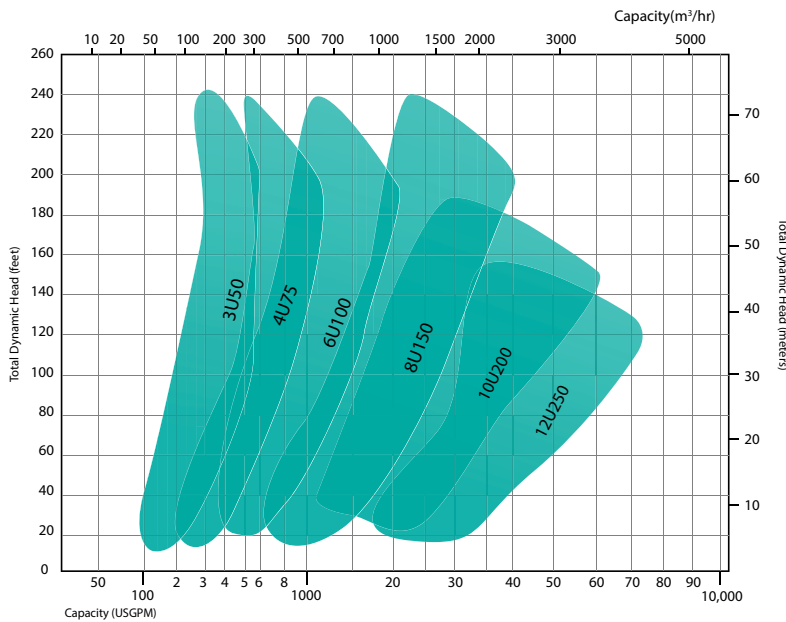

PROFILE

Discharge range: 2" to 10" [50 mm to 250 mm]

Heads to: 240 ft [73 m]

Flows to: 6,000 gpm [1,350 m³/hr]

Working pressures to: 150 psig [1030 kPa]

Typical Applications

- Sand and gravel
- Industrial
- Cyclone Feed
- Pulp & Paper

FEATURES

- Variety of high efficiency and non-clog impeller designs with pump-out vanes on shrouds to improve seal performance
- Zero leakage pumping available with Schurco Expeller Seals that do not require seal water
- Diverse range of materials for all wet end components to maximize operational life in abrasive or corrosive slurries
- Straightforward clamp removal allows for simplified impeller removal
- Oversized shaft diameters and reduced overhang in the wet-end contribute to long life and reliability from drive-end in the field

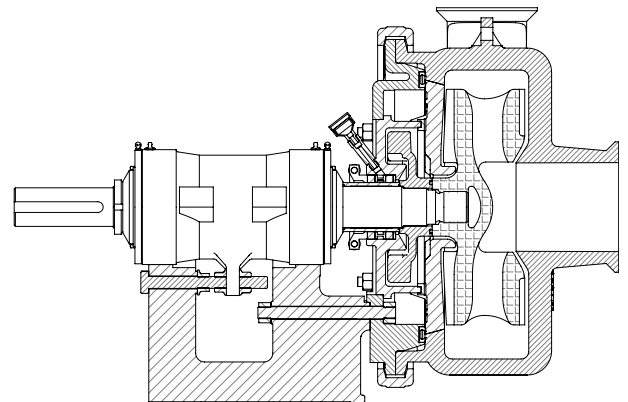

P Series

Ideal for use in “dirty water” and light slurry applications, this pump series provides the end user with the ultimate in reliability.

The P Series pump is ideal for process chemical slurry or mine dewatering applications where solids may be present, but in lower concentrations where legacy process chemical pumps get eaten away by the light solids. Diverse metallurgy options allow this pump to be applied across a wide range of chemical applications.



HYDRAULIC COVERAGE

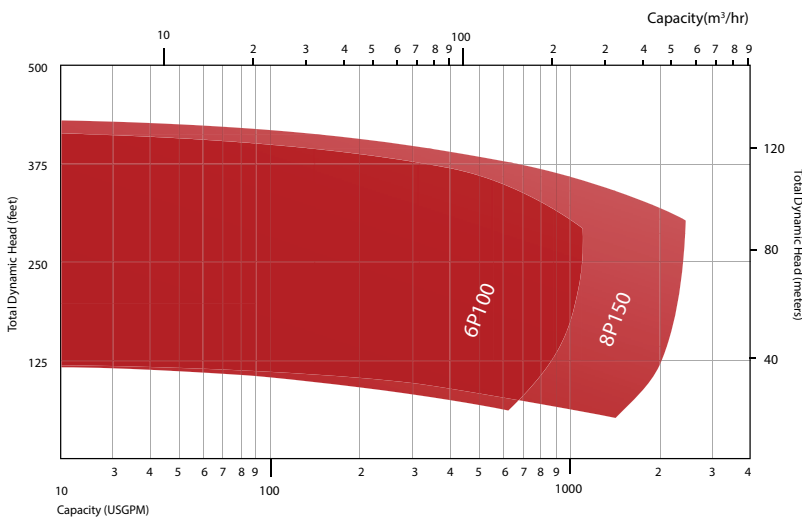

PROFILE

Discharge range: 4" to 6" [25 mm to 450 mm]

Heads to: 420 ft [128 m]

Flows to: 2,250 gpm [510 m³/hr]

Working pressures to: 240 psig [1650 kPa]

Typical Applications

- Mine dewatering
- Process water
- Dirty water, high head

FEATURES

- Provide greater reliability and durability than typical process pumps
- Front pull-out or back pull-out allows for rapid replacement without pipework being disrupted
- Zero leakage pumping available with Schurco Expeller Seals that do not require seal water
- Diverse range of metallurgical materials for all wear components to maximize operational life in abrasive or corrosive slurries
- Oversized shaft diameters and reduced overhang in the wet-end contribute to long life and reliability from drive-end in the field
- Oil bath lubrication in the bearing frame allows for high operating speeds and associated head pressure

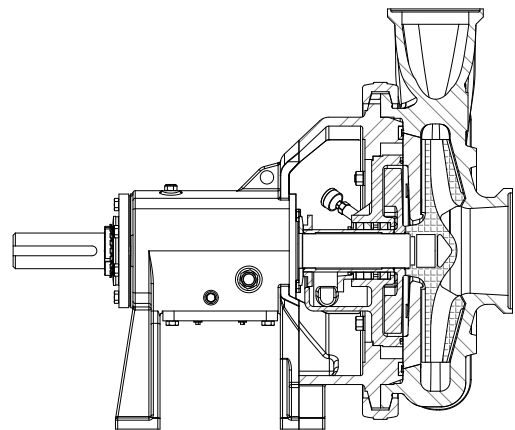

Z Series

Rough and ready, this large solids capacity design is perfect for dredging or large particle pumping.

With large particle passages with exceptionally good NPSHr characteristics, the Z Series delivers extreme performance in large solids pumping applications. The Z Series can be applied with both equal and unequal suction to discharge nozzle sizes as applications may require, e.g. 10"x10" or 12"x10". Built around the same power frame as the rest of the heavy-duty Schurco pump line, these pumps are workhorses for large solids.



HYDRAULIC COVERAGE

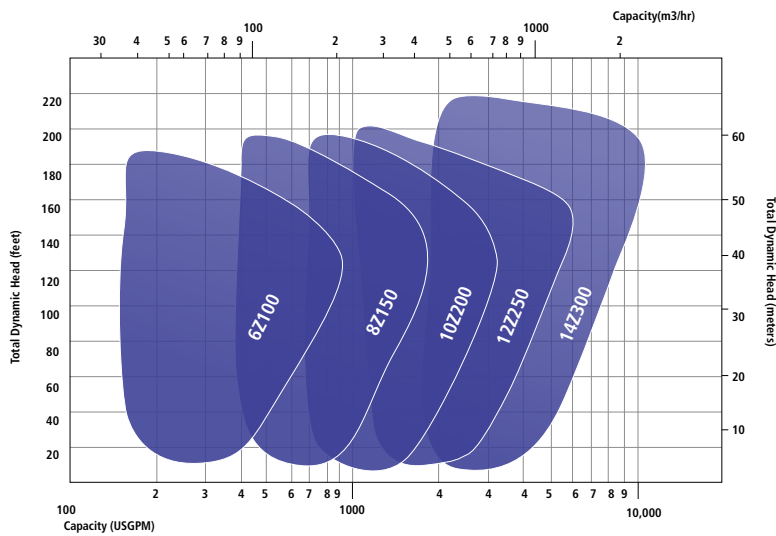

PROFILE

Discharge range: 4" to 14" [100 mm to 350 mm]

Heads to: 225 ft [70 m]

Flows to: 12,000 gpm [2,730 m3/hr]

Working pressures to: 200 psig [1380 kPa]

Typical Applications

- Sand and gravel
- Slag granulation
- Dredging
- Hydraulic mining
- Large particle applications
- Sugar beets
- Low NPSHa applications

FEATURES

- Oversized pump casing designed to reduce internal particle velocities increasing wear life
- Wide three-vane style impellers are standard, and pass extremely large solids
- Impeller expelling vanes reduce gland pressure and intrusion of solids in gland area
- Balanced efficiency and wear life for applications with coarse highly abrasive material
- Zero leakage pumping available with Schurco Expeller Seals that do not require seal water
- Oversized shaft diameters and reduced overhang in the wet-end contribute to long life and reliability from drive-end in the field

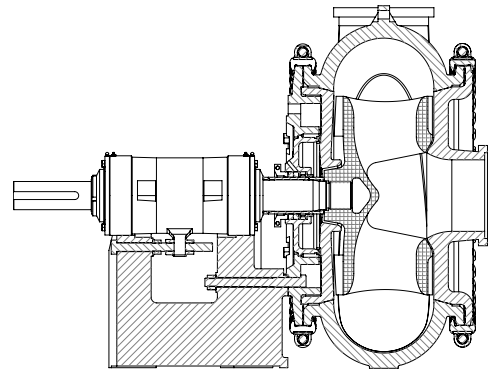

Vertical Pump Components

METAL WET END

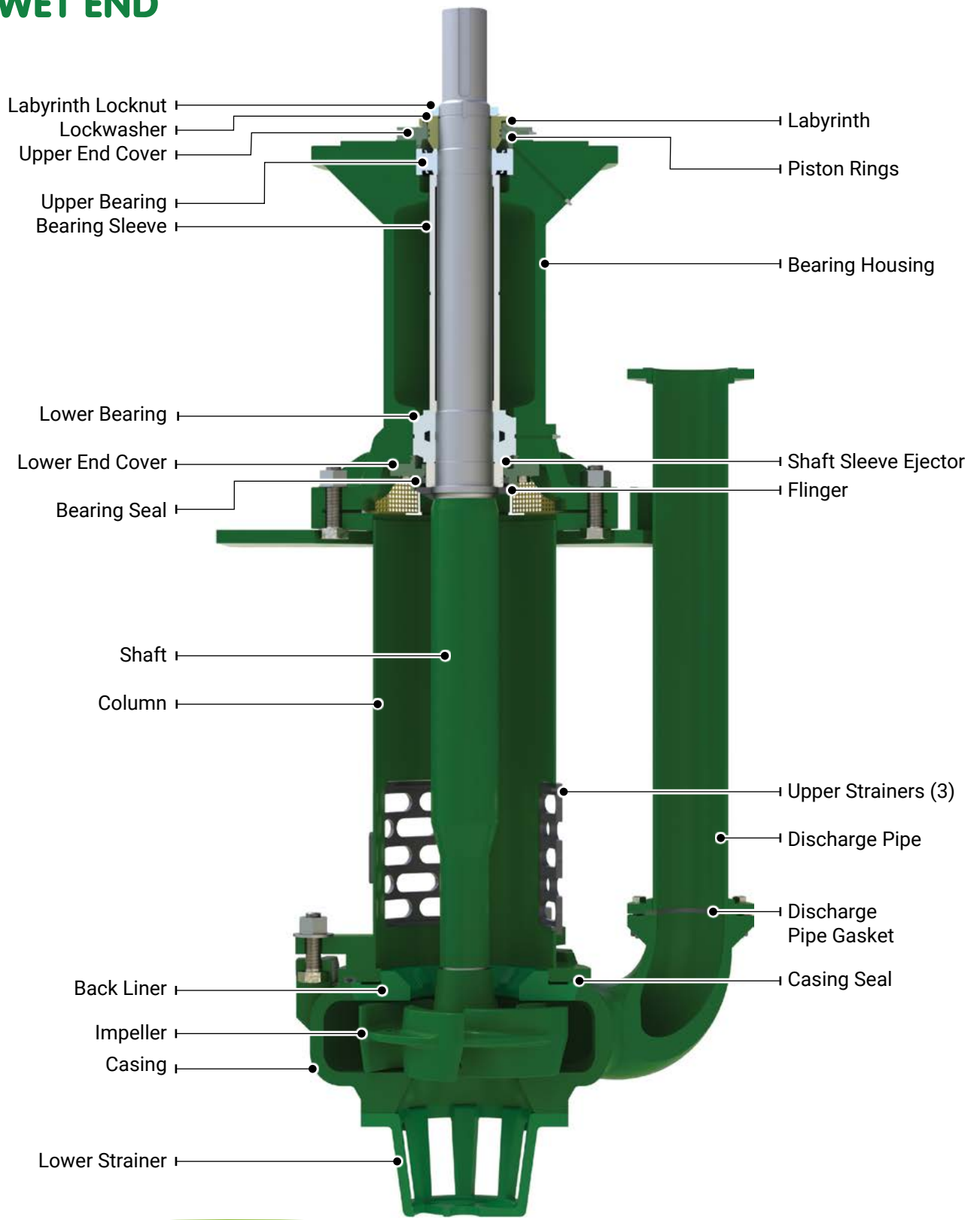

ELASTOMER WET END

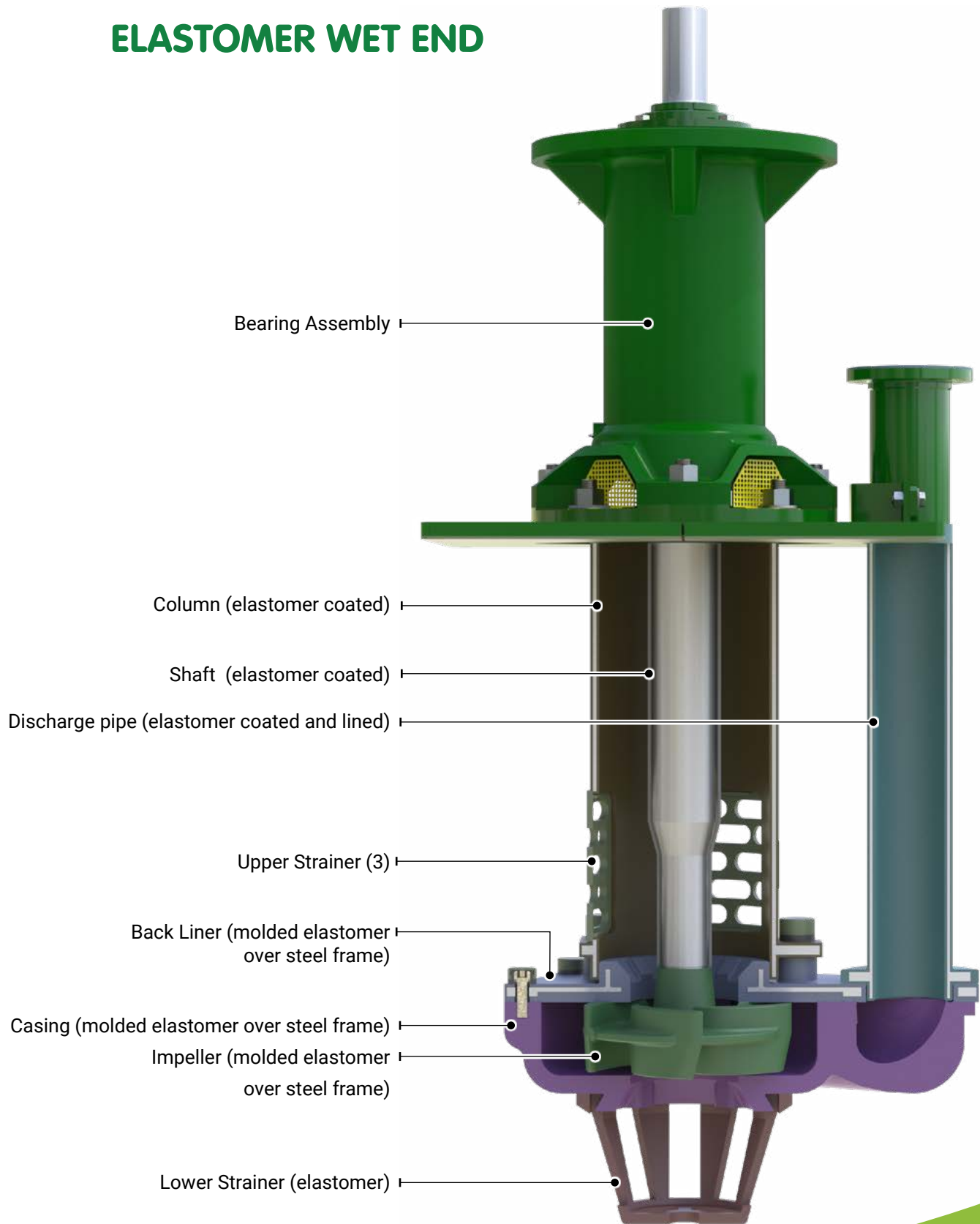

V Series

Fully-cantilevered pump design, with no submerged bearings; can operate completely dry with no ill effect.

A true cantilever pump available in alloy and elastomer wet-end material options that operates well in a variety of sump conditions or on floating dewatering platforms. The pump features no submerged bearings or seals thus eliminating the primary mode of failure in centrifugal slurry pumping.



HYDRAULIC COVERAGE

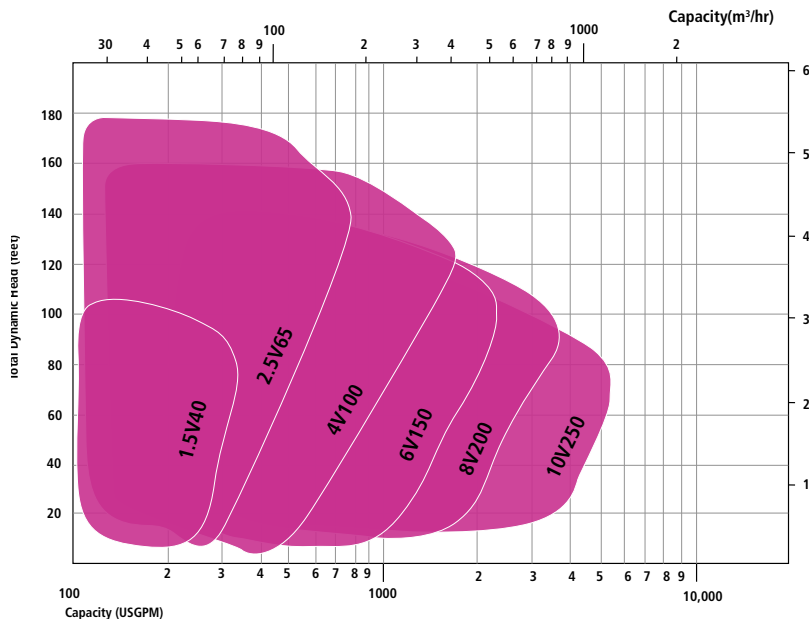

PROFILE

Discharge range: 1-1/2" to 10" [40 mm to 250 mm]

Heads to: 160 ft [50 m]

Flows to: 6,000 gpm [1,350 m³/hr]

Typical Applications

- Sand and gravel
- Effluent handling
- Floor pumps
- Sump pumps
- Coal prep
- Mineral processing

FEATURES

- Balanced efficiency and wear life for applications with highly abrasive material; can pump up to 60% (w/w) solids
- Cantilevered depth to 12 ft (3600 mm) with suction extension pipe
- Heavy-duty open style impellers draw suction from top and bottom balancing the load and delivering smooth vibration free operation
- Torque-flow/recessed impellers available, allowing passage of large solids with minimal particle contact
- Due to lack of lower seal the pump has a dry-running capability ("snore" mode)
- Agitator option available designed to keep solids suspended around suction.

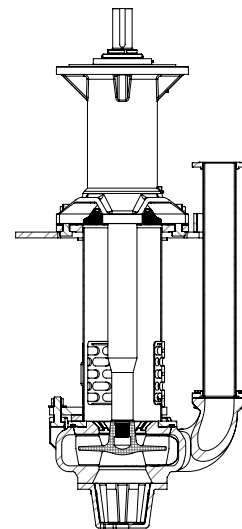





For local sales and service call:

9410 Florida Mining Boulevard E.
Jacksonville, Florida 32257
United States of America
904.356.6840
schurcoslurry.com